

Further technical data for HORST1000 robot system.

Technical data version: V241106

1 Technical Data - HORST1000

Robot	HORST1000
Number of axes	6
Nominal load	8 kg
Max. range	1018 mm
Repeatability	+/- 0.05 mm
Protection classification	IP54
Sound level	<70 dB (A)
Weight	approx. 70 kg
Power supply	230 V AC, 50-60 Hz
Ambient temperature	5-40 °C
Installation area	380 x 380 mm
Base drilling pattern	300 x 300 mm
Standard color	RAL 5021 (water blue)

Information on load capacity

The nominal load is determined in accordance with VDI 2861-2. The load center of gravity has a defined distance from the robot flange (for HORST1000: $L_{xy} = 64$ mm; $L_z = 111$ mm). The nominal load can be moved with these distances of the load center of gravity without restrictions in the entire working area of the robot.

It is possible to move loads above the nominal load with the robot. This is possible if the load is attached closer to the robot flange or by restricting the robot's working area. Please consult fruitcore robotics if loads greater than the nominal load are to be moved.

2 Axis data HORST1000

Axis	Range of movement	Speed (With a payload of 0 kg; rounded down)
1	+/- 176°	225 °/s
2	+103° / +5°	95 °/s
3	+57° / -66°	280 °/s
4	+/- 171°	980 °/s
5	+/- 119°	880 °/s
6	+/- 300°	1150 °/s

 The maximum axis speeds were determined with a payload of 0 kg as this is the only way to ensure that the measured values can be compared properly. At maximum payload, the maximum speed can vary greatly since it depends directly on the position of the center of mass. The maximum speed at 0 kg payload, on the other hand, is unambiguous as the influence of the center of mass of a payload does not apply.

In general, speed is rather less suitable as a basis of decision-making in robot selection, as it only shows the actual performance of a robot to a limited extent. Depending on the range of motion and the motion profile of the application, high accelerations, for example, can have a significantly greater influence on cycle time and economic efficiency than speed. It is therefore recommended to analyze the application with the corresponding framework conditions by using [horstOS Simulation](https://horstcosmos.com/horstfx/options)¹ or via a feasibility analysis, for example.

¹ <https://horstcosmos.com/horstfx/options>

3 Technical Data Control

Dimensions (H x W x D)	313 mm x 174 mm x 446 mm
Weight	ca. 10 kg
Protection classification	IP20
I/O connections on switch cabinet	20 digital inputs (expandable to 28) 18 digital outputs (expandable to 30)
I/O connections on tool flange	2 digital inputs and outputs each M8 male, 4-pin, angled, A-coded
I/O power supply	24 V / 7 A at control 24 V / 2.5 A at tool flange
Communication	TCP/IP 100-Mbit/s Ethernet (Sockets), Primary interface (XML-RPC) (The primary interface (XML-RPC) is activated via the “Advanced Interfaces” software option)
Fieldbuses	Modbus/TCP, Profinet (The interfaces Modbus/TCP and Profinet are activated via the “Advanced Interfaces” software option)
Safety-relevant Interfaces (2 channels each)	Emergency stop [input and output] Safety stop [input and output] In accordance with DIN EN ISO 10218-1; PL d. + 4 config. safe inputs (also configurable as 8 digital inputs) + 6 config. safe outputs (including 2 potential-free contacts)
USB ports	2x USB port 3.0
Wiring of HORST	3 m cable between robot and switch cabinet
Wiring of operating panel	5 m cable between operating panel and switch cabinet

4 HORST1000 Base drilling pattern

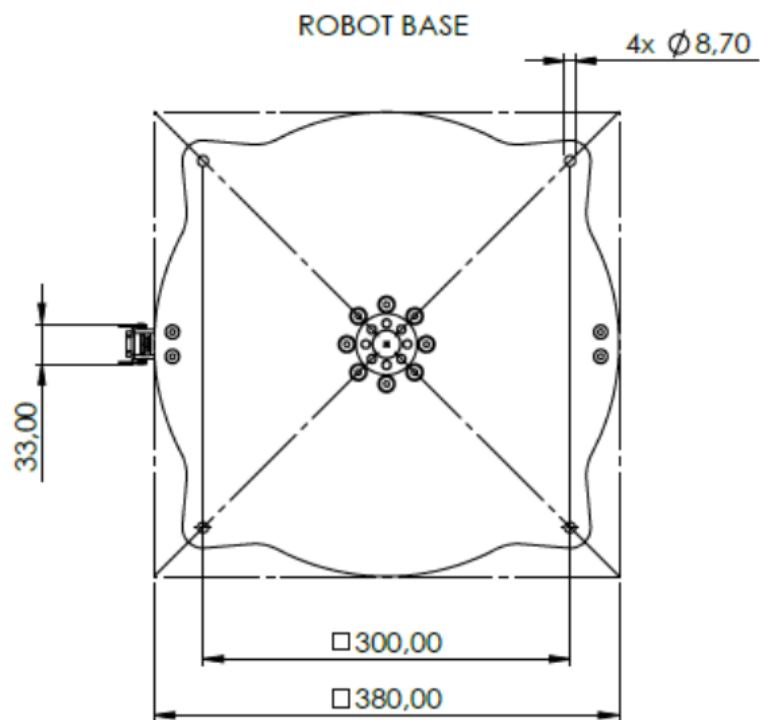

Dimensions of the installation area and base drilling pattern of HORST1000

5 HORST1000 Robot flange

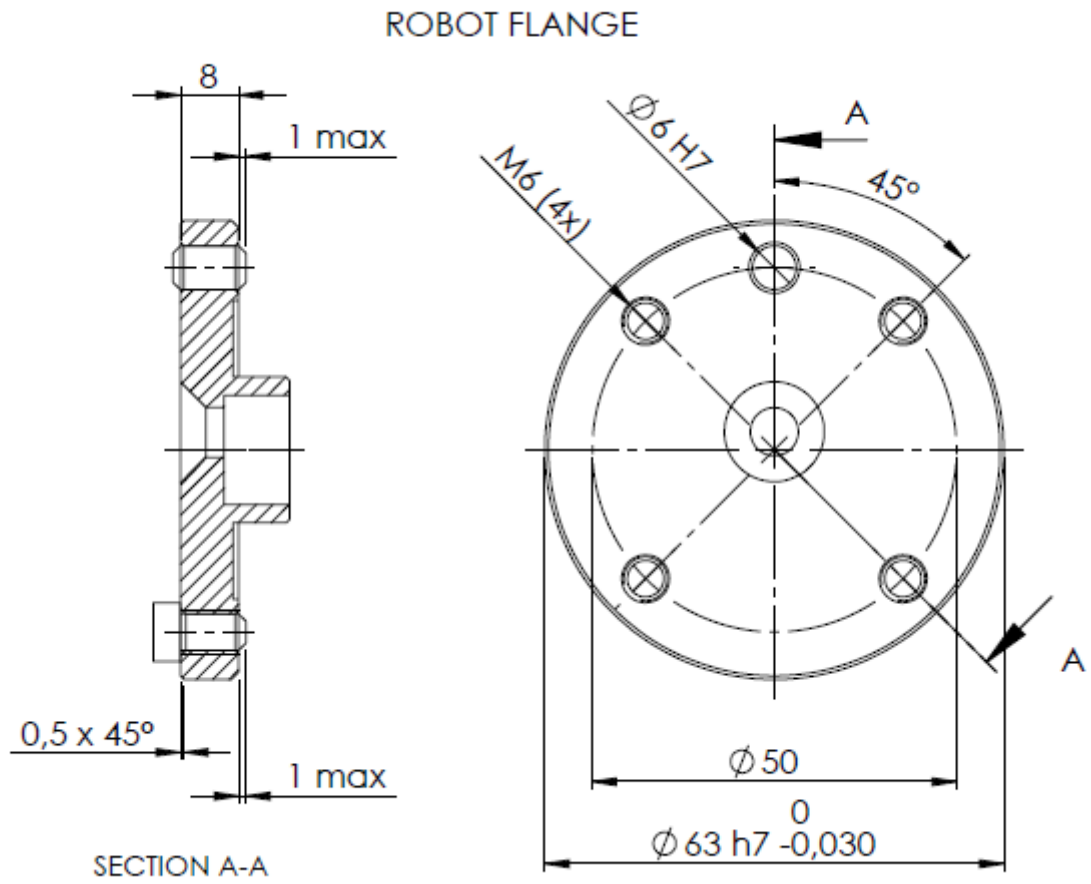

Robot flange of HORST1000

6 HORST1000 Workspace

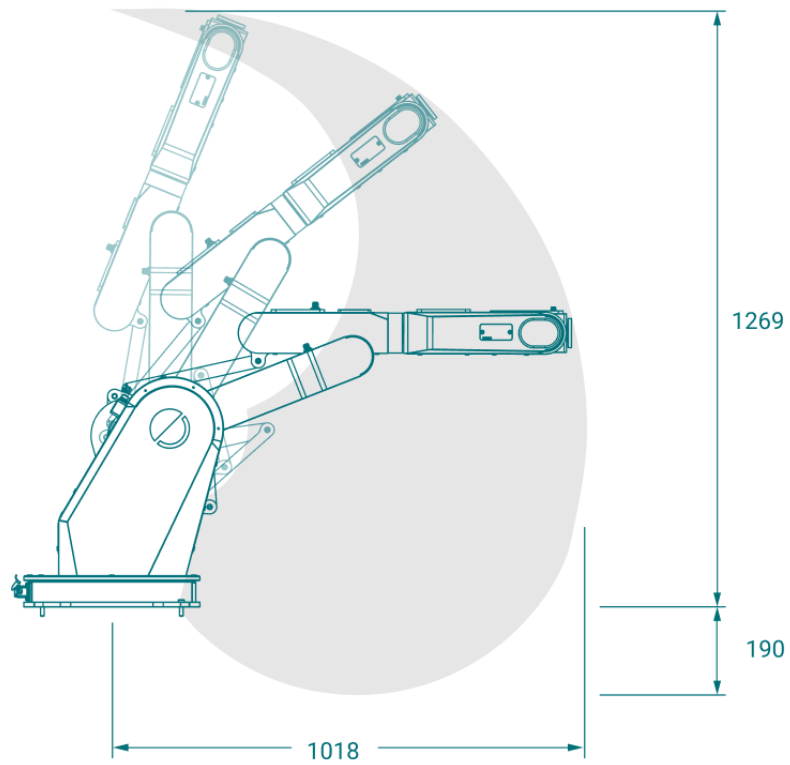

HORST1000 workspace: Lateral section

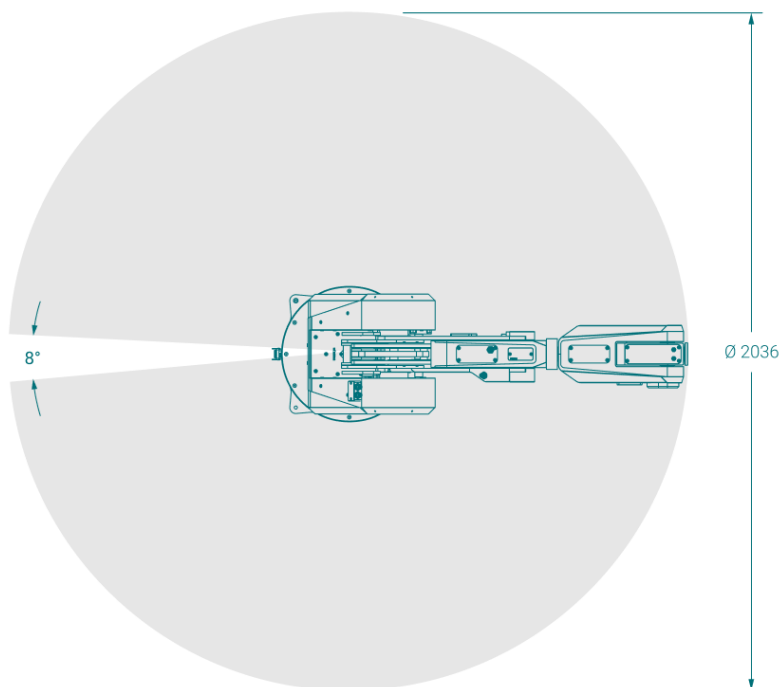

HORST1400 workspace: Top view

7 Fastening attachments and external energy chains

Accessory flange plates can be used for attachments that are to be mounted on the robot arm (e.g. pneumatic valves). Bolt-on points with hole spacings of 45 mm, 50 mm and 60 mm are available on the robot. The flange plate is designed with slotted holes and can therefore be used universally. The flange plates are optional accessories and are not included as standard in the scope of delivery of a robot system.

Dimensioning of the accessory flange plate:

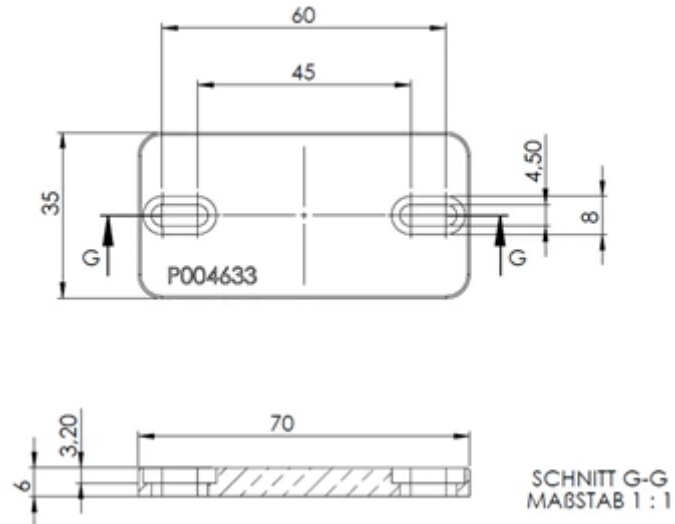

Positions of the holes for attachments on HORST1000:

